

Trademarks

LAUNCH is a registered trademark of LAUNCH TECH CO., LTD. in China and other countries. All other marks are trademarks or registered trademarks of their respective holders.

Copyright Information

Copyright © 2024 by LAUNCH TECH CO., LTD. (also called LAUNCH for short). All rights reserved. No part of this publication may be reproduced, stored in a retrieval system, or transmitted in any form or by any means, electronic, mechanical, photocopying and recording or otherwise, without the prior written permission.

Statement: LAUNCH owns the complete intellectual property rights for the software used by this product. For any reverse engineering or cracking actions against the software, LAUNCH will block the use of this product and reserve the right to pursue their legal liabilities.

Disclaimer of Warranties and Limitation of Liabilities

All information, illustrations, and specifications in this manual are based on the latest information available at the time of publication.

The right is reserved to make changes at any time without notice. We shall not be liable for any direct, special, incidental, indirect damages or any economic consequential damages (including the loss of profits) due to the use of the document.

Using This Manual

This manual contains device usage instructions.

Some illustrations shown in this manual may contain modules and optional equipment that are not included in your system.

The following conventions are used.

Bold Text

Bold text is used to highlight selectable items such as buttons and menu options.

Example:

Tap **OK**.

Notes

A NOTE provides helpful information such as additional explanations, tips, and comments.

Example:

 Note: Remember to remove the VCI connector from the vehicle's DLC after use.

Warning

Warning indicates a hazardous situation which, if not avoided, could result in minor or moderate injury to the operator or to bystanders.

Example:

 Warning: Retrieving and using DTCs for troubleshooting vehicle operation is only one part of an overall diagnostic strategy. Never replace a part based only on the DTC definition. Each DTC has a set of testing procedures, instructions and flow charts that must be followed to confirm the location of the problem. This information can be found in the vehicle's service manual.

Danger

Danger indicates an imminently or potentially hazardous situation which, if not avoided, could result in death or serious injury to the operator or to bystanders.

Example:

 Danger: If you must drive the vehicle in order to perform a troubleshooting procedure, always have a second person help you. Trying to drive and operate the diagnostic tool at the same time is dangerous, and could cause a serious traffic accident.

Illustrations

Illustrations used in this manual are samples, the actual testing screen may vary for each vehicle being tested. Observe the menu titles and on-screen instructions to make correct option selection.

Important Safety Precautions

To avoid personal injury, property damage, or accidental damage to the product, read all of the information in this section before using the product.

DANGER

- When an engine is operating, keep the service area well-ventilated or attach a building exhaust removal system to the engine exhaust system. Engines produce various poisonous compounds (hydrocarbon, carbon monoxide, nitrogen oxides, etc.) that cause slower reaction time and result in death or serious personal injury.
- Please use the included battery and power adapter. Risk of explosion if the battery is replaced with an incorrect type.
- If you must drive the vehicle in order to perform a troubleshooting procedure, always have a second person help you. Trying to drive and operate the diagnostic tool at the same time is dangerous, and could cause a serious traffic accident.

WARNING

- Always perform automotive testing in a safe environment.
- Do not connect or disconnect any test equipment while the ignition is on or the engine is running.
- Before starting the engine, put the gear lever in the Neutral position (for manual transmission) or in the Park (for automatic transmission) position to avoid injury.
- NEVER smoke or allow a spark or flame in vicinity of battery or engine. Do not operate the tool in explosive atmospheres, such as in the presence of flammable liquids, gases, or heavy dust.
- Keep a fire extinguisher suitable for gasoline/chemical/electrical fires nearby.
- Wear an ANSI-approved eye shield when testing or repairing vehicles.
- Put blocks in front of the drive wheels and never leave the vehicle unattended while testing.
- Use extreme caution when working around the ignition coil, distributor cap, ignition wires and spark plugs. These components create hazardous voltage when the engine is running.
- To avoid damaging the tool or generating false data, please make sure the vehicle battery is fully charged and the connection to the vehicle DLC (Data Link Connector) is clear and secure.
- Retrieving and using DTCs for troubleshooting vehicle operation is only one part of an overall diagnostic strategy. Never replace a part based only on the DTC definition. Each DTC has a set of testing procedures, instructions and flow charts that must be followed to confirm the location of the problem. This information can be found in the vehicle's service manual.
- Automotive batteries contain sulfuric acid that is harmful to skin. In operation, direct contact with the automotive batteries should be avoided. Keep the ignition sources away from the battery at all times.
- Keep the tool dry, clean, free from oil, water or grease. Use a mild detergent on a clean cloth to clear the outside of the equipment when necessary.
- Keep clothing, hair, hands, tools, test equipment, etc. away from all moving or hot engine parts.
- Store the tool and accessories in a locked area out of the reach of children.
- Do not use the tool while standing in water.
- Do not expose the tool or power adapter to rain or wet conditions. Water entering the tool or power adapter increases the risk of electric shock.
- This tool is a sealed unit. There are no end-user serviceable parts inside. All internal repairs must be done by an authorized repair facility or qualified technician. If there is any inquiry, please contact the dealer.
- Keep the tool far away from magnetic devices because its radiations can damage the screen and erase the data stored on the tool.
- Do not attempt to replace the internal rechargeable lithium battery. Contact the dealer for factory replacement.

- Do not disconnect battery or any wiring cables in the vehicle when the ignition switch is on, as this could avoid damage to the sensors or the ECU.
- Do not place any magnetic objects near the ECU. Disconnect the power supply to the ECU before performing any welding operations on the vehicle.
- Use extreme caution when performing any operations near the ECU or sensors. Ground yourself when you disassemble PROM, otherwise ECU and sensors can be damaged by static electricity.
- When reconnecting the ECU harness connector, be sure it is attached firmly, otherwise electronic elements, such as ICs inside the ECU, can be damaged.

Compliance Information

FCC ID: XUJOADDPD1302

This device complies with part 15 of the FCC Rules. Operation is subject to the following two conditions:

(1) This device may not cause harmful interference, and (2) this device must accept any interference received, including interference that may cause undesired operation.

Any changes or modifications not expressly approved by the party responsible for compliance could void the user's authority to operate the equipment.

Note: This equipment has been tested and found to comply with the limits for a Class A digital device, pursuant to part 15 of the FCC Rules. These limits are designed to provide reasonable protection against harmful interference when the equipment is operated in a commercial environment. This equipment generates, uses, and can radiate radio frequency energy and, if not installed and used in accordance with the instruction manual, may cause harmful interference to radio communications. Operation of this equipment in a residential area is likely to cause harmful interference in which case the user will be required to correct the interference at his own expense.

The device has been evaluated to meet general RF exposure requirement at 0mm for body worn condition. The highest reported SAR for stand-alone and simultaneous transmission exposure conditions are below the maximum value. End-users must be informed of the operating requirements for satisfying RF exposure compliance.

This device is in compliance with the essential requirements and other relevant provisions of Radio Equipment Directive 2014/53/EU. The RF frequencies can be used in Europe without restriction.

TABLE OF CONTENTS

1 Introduction	1
1.1 Product Profile	1
1.2 Package List	1
1.3 Components & Controls	1
1.3.1 Diagnostic Tablet	1
1.3.2 VCI	3
1.4 Technical Specifications	4
2 Initial Setup	5
2.1 Charging & Powering On	5
2.2 Screen Layout	5
2.3 Adjusting Screen Brightness	5
2.4 Changing Language	5
2.5 Network Setup	5
3 Register & Update	7
3.1 Register & Update	7
3.2 Home Screen	9
4 Connections	11
4.1 Preparation	11
4.2 Vehicle Connection	11
4.3 Communication Setup	11
5 Diagnosis	13
5.1 Smart Diagnose (Auto Detect)	13
5.2 Manual Diagnose (Scan Vehicle)	15
5.3 Remote Diagnose (Tech 2 Tech)	21
5.3.1 Adding Friends	22
5.3.2 Start Instant Messaging	22
5.3.3 Launch Remote Diagnosis (Scanner-To-Scanner)	23
5.3.4 Launch Remote Diagnosis (Based on Web-based Remote Diagnostics Platform)	24
5.4 I/M Readiness	26
5.5 Diagnostic History	26
5.6 Diag. Feedback	27
6 Service Function (Reset)	28
7 Software Update	29
7.1 Update Diagnostic Software & APP	29
7.2 Update Frequently Used software	29
7.3 Renew Subscription	29
8 Toolbox	30
8.1 ADAS (Calibration)	30
8.2 Analyze Battery (BST360)	30
8.3 Video Scope	30
8.4 Oscilloscope	30
8.5 Sensor Simulator	30
8.6 Multimeter	30
8.7 X-431 TSGUN (TPMS)	30
9 Reports	31
10 X-431 Settings	32
10.1 General	32
10.1.1 Units	32
10.1.2 Expiration Reminder	32
10.1.3 Diagnostic Software Auto Update	32

10.1.4 Diagnostic Application Auto Update	32
10.1.5 Display shop information on reports.....	32
10.1.6 Aggregated report service	32
10.2 VCI	32
10.3 VCI Management	32
10.4 Account & Shop Information	32
10.4.1 Profile	32
10.4.2 Shop Information	32
10.4.3 Technician	33
10.4.4 Change Password.....	33
10.4.5 Log Out	33
10.5 Manage Subscriptions.....	33
10.6 Display	33
10.6.1 Icon size	33
10.6.2 Color Theme.....	33
10.6.3 Software display	33
10.7 Manage Software Data	33
10.7.1 Hide & Remove Software.....	33
10.7.2 Backup	33
10.7.3 Restore.....	33
10.7.4 Clear Diagnostic Application Cache	33
10.7.5 Sample	33
10.8 Printer set	33
10.9 About.....	35
11 J2534 Reprogramming Using SmartLink C	36
12 FAQ.....	37

1 Introduction

1.1 Product Profile

This Android OS-based, tablet-style diagnostic tool incorporates the best possible coverage of OE-level diagnostics with multitasking capable software.

Using the powerful Octa-core 2GHz processor, 12G RAM, and a 13.6" IPS capacitive touch screen with a resolution of 2560 x 1600 pixels, it delivers quick and complete diagnostic functionalities which technicians need to diagnose, research and repair vehicles in one solution.

1.2 Package List

Common accessories are same, but for different destinations, the accessories may vary. For detailed accessory items, please consult from the seller or check the packing list supplied with this tool together.

No.	Item	Description	Qt.
1	Diagnostic tablet	Indicate the test results.	1
2	SmartLink C V3.0 VCI device	Connect to vehicle's DLC (Data Link Connector) port to access vehicle's live data.	1
3	Diagnostic cable	Connect the VCI to vehicle's DLC port. It can be separated into two parts: DB15F to HD15F data cable and HD15M to OBD16 adapter.	1
4	Power adapters	Charge the display tablet.	4
5	Type A to Type B data cable	Connect the VCI to the tablet to perform vehicle diagnosis.	1
6	Type A to Type C data cable	Connect the VCI to the PC for data exchange.	1
7	Password envelope	A piece of paper bearing Product S/N and Activation Code, which is needed for product registration.	1
8	Crossover cable	Connect the VCI device to the modem when performing SmartLink Super Remote Diagnostics.	1
9	Mini-HDMI to HDMI cable	Connect to an external projector or monitor with HDMI interface.	1
10	Quick start guide		1

1.3 Components & Controls

There are two main components to the diagnostic system:

- Diagnostic Tablet – the central processor and monitor for the system (See Chapter 1.3.1).
- VCI (Vehicle Communication Interface) – the device for accessing vehicle data (See Chapter 1.3.2).

1.3.1 Diagnostic Tablet

The tablet acts as the central processing system, which is used to receive and analyze the live vehicle data from the SmartLink C device and then output the test result.

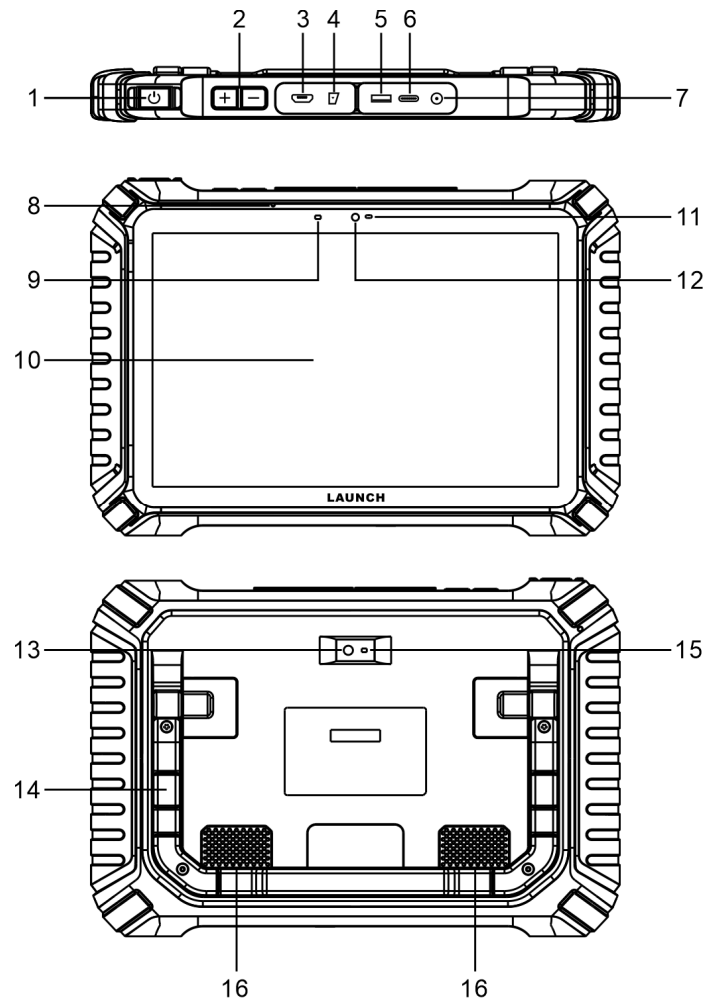

1. Power/Screen Lock Button

Turn the tablet on/off with long press, or lock the screen with short press.

2. Volume Buttons

Adjust the volume.

3. High Definition Multimedia Output Port

Connect to an external projector or monitor.

4. Memory Card Slot

Store the memory card for storage expansion.

5. Data Transmission Port

Reserved for add-on modules, and other USB devices use only.

6. Type-C Charging Port

Reserved for charging or transferring data.

7. DC IN Port

Connect the power adapter to charge the tablet.

8. Microphone

9. Charging indicator

It illuminates red while the tablet is charging. Once charging is finished, it will illuminate solid green.

10. Touch Screen

11. Ambient Light Sensor

12. Front Camera

13. Rear Camera

14. Adjustable Kickstand

Flip out it to any angle and work comfortable at your desk, or hang it on automotive part.

15. Camera Flash

16. Audio Speaker

1.3.2 VCI

The SmartLink C V3.0 device features powerful functions and it can be applied in the following situations:

- 1). When as a VCI (Vehicle Communication Interface), it needs to work in conjunction with the **Diagnose** module of the tablet, which is used to obtain vehicle data, and then send it to the tablet for analysis wirelessly or via data cable.
- 2). When as a local J2534 PassThru device, it can be used in conjunction with the PC installed with OEM diagnostic software.

 Note: For detailed operations, please refer to Chapter 11.

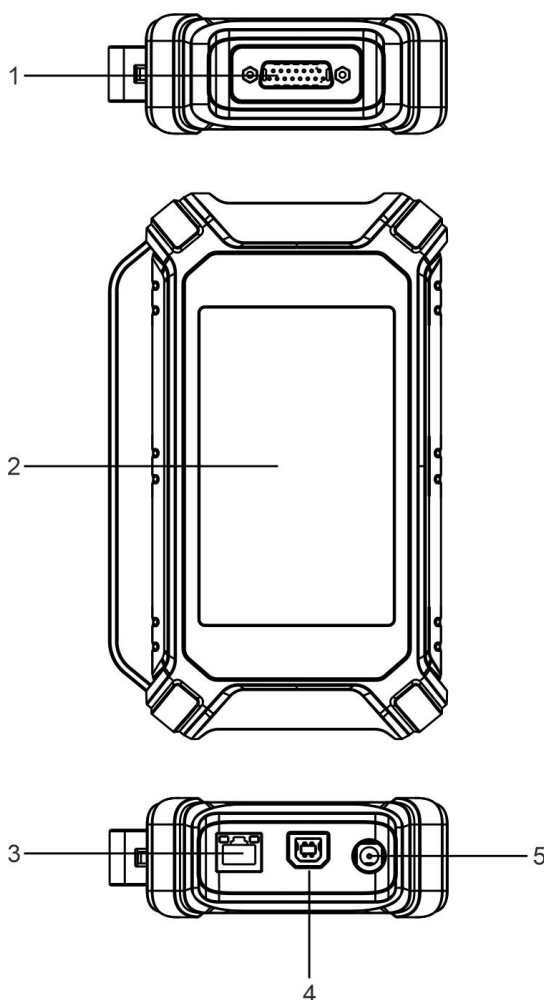

1. DB-15 diagnostic connector

Connect it to the vehicle's DLC (Data Link Connector) port via the diagnostic cable.

2. Touch screen

3. LAN/WAN port

Connect it to the modem via the crossover cable. It only applies to the SmartLink Super Remote Diagnostics.

4. Data I/O port

- Connect it to the tablet to perform vehicle diagnosis.

- Connect it to the PC to perform J2534 reprogramming when as a J2534 PassThru device.

5. DC-IN power jack

It can obtain power via connecting the diagnostic cable to the vehicle's DLC port or connecting to an external DC power supply.

⚠ Warning: The SmartLink C V3.0 device obtains power through the vehicle's DLC via the DB-15 diagnostic connector. DO NOT connect this power jack to an external DC power supply when the SmartLink C V3.0 device is properly connected to the vehicle's DLC port. No responsibility can be assumed for any damage or loss caused as a result of not strictly following the warning.

1.4 Technical Specifications

1. Display tablet

Operating system: Android

CPU: Octa-core processor, 2.0GHz

Display: 13.6 inch IPS capacitive touch screen with 2560 x 1600 resolution

Memory: 12GB

Hard disk: 512GB

Connectivity:

- Wi-Fi: 2.4G/5GHz dual frequency
 - Universal serial BUS ports (1 x Type-C + 1 x Type-A)
- Camera: front-facing 8MP + 20MP rear-facing camera (Auto focus)

HDMI: MicroHDMI out

Operating Temperature: 0°C ~ 50°C

Storage Temperature: -20°C ~ 70°C

2. VCI (Vehicle Communication Interface)

Display: 3.95 inch TFT screen with 320 x 480 resolution

Working voltage: DC 9~36V

Communication: wireless and wired

Size: 197mm x 108mm x 43mm

Working temperature: 0°C~ 50°C

2 Initial Setup

2.1 Charging & Powering On

Notes:

- Only use the included power adapter to recharge the tablet. Use of any other adapter will damage the tool. We assume no responsibility for damage or loss resulting from using other similar adapters other than the specified one.
- Always charge on a non-flammable surface in a well-ventilated area.

To check the battery power level, press and hold the Power button about 3 seconds to turn on the tablet. Power level is indicated as a percentage in the upper right corner of the screen. If the power level drops below 10% while the tablet is on, a “Connect Charger” notification will appear on the screen.

1. Connect one end of the power adapter to the DC IN port of the tablet, and the other end to the AC outlet.
2. The charging LED illuminates solid red and the charging symbol will appear on the screen.
3. Once it illuminates solid green, it indicates that the battery is fully charged and the charging complete symbol  replaces the charging symbol. Disconnect the power adapter from the AC outlet.
4. Press and hold the **POWER** button for about 3 seconds to turn on the tablet. The system starts initializing and then enters the home screen.

To turn the tablet off, press and hold the **POWER** button until an option menu appears. Tap **Power Off**.

2.2 Screen Layout

On-screen keys and status bar on the bottom of the screen are as follows:

Tap  to return to the previous screen or exit the application.

Tap  to jump to the home screen.

Tap  to display a list of applications that are currently running or recently used.

Tap  to capture the current screen and all captured screenshots are stored in the Screenshots folder.

 shows whether the VCI is connected properly or not.

2.3 Adjusting Screen Brightness

The tablet is equipped with a built-in light intensity sensor. It can adjust the screen brightness according to the ambient light intensity automatically. Alternatively, you can also adjust it manually.

1. On the home screen, tap **Settings -> Display -> Brightness level**.
2. Drag the slider to adjust it.

Alternatively, user may also slide the **Automatically brightness** switch to ON, and the system will automatically adjust the screen brightness.

 Note: Reducing the brightness of the screen is helpful to save the power of the tablet.

2.4 Changing Language

The tablet supports multiple languages. To change the language of the tablet, please do the following:

1. On the home screen, tap **Settings -> System -> Language & input -> Languages**.
2. Tap the desired language from the list and the system will change to the chosen language.

2.5 Network Setup

The tablet has built-in Wi-Fi that can be used to get online. Once you're online, you can register the tablet, browse the

LAUNCH

Internet, get and update apps on your network.

 Note: Once WLAN is set as ON, the tablet will consume more power. While WLAN keeps unused, please turn it off to conserve battery power.

1. On the home screen, tap **Settings -> Network & internet -> Internet -> Wi-Fi**.
2. Tap or slide the Wi-Fi switch to ON, the tablet starts searching for all available wireless LANs.
3. Choose the desired Wi-Fi access point / network,
 - If the network you chose is open, you can connect directly.
 - If the selected network is encrypted, you have to enter the right security key (network password).

When this tool is in range, it will connect to the previously linked network automatically.

3 Register & Update

For new users, you will need to experience a user registration process before getting started.

3.1 Register & Update

After the tablet is initialized, tap the **Login** button on the upper right corner of the home screen, the following screen will appear:

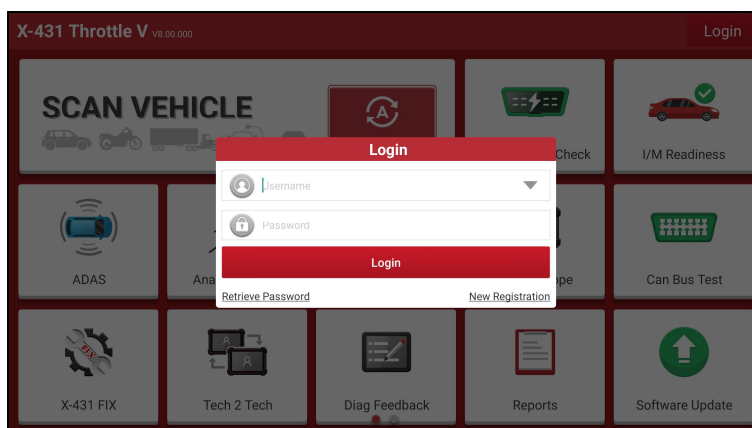

(If you are a new user, follow **A** to proceed.)

(If you have registered to be a member, go to **B** to login the system directly.)

(In case you forgot password, refer to **C** to reset a new password.)

A. If you are a new user, tap **New Registration** to enter sign-up page.

1. Create an App Account: Input the information to create a new account (all fields must be completed). When finished tap **Register**, the following screen will appear:

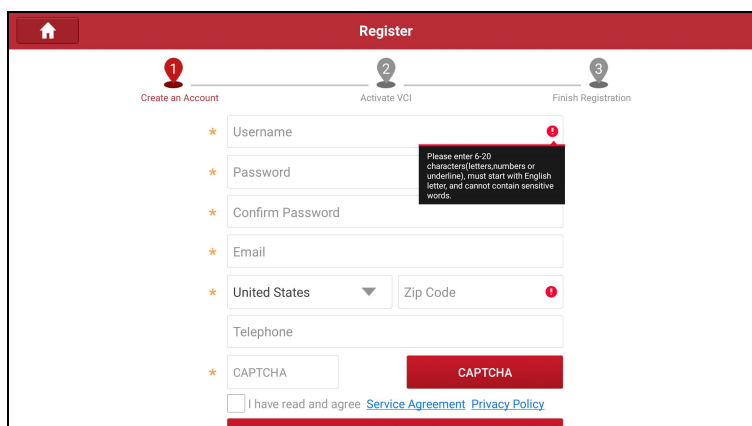

2. Activate VCI: Input the Product Serial Number and Activation Code, and tap **Activate** to go to the next step.

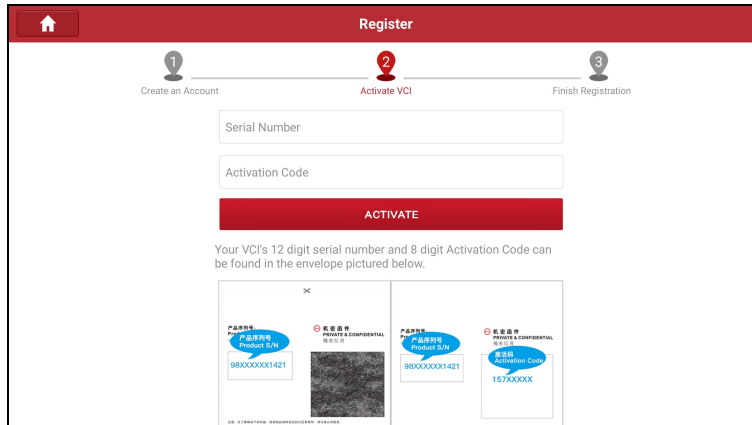

Input the Product Serial Number and Activation Code can be found in the supplied Password Envelope.

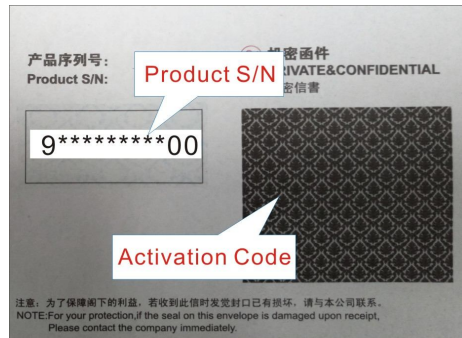

Note: To exit and activate it later, tap **Skip**. In this case, you can activate the VCI by tapping X-431 **Settings** -> **VCI** -> **Activate VCI**.

After the registration is successfully complete, the wireless communication between the tablet and the VCI device is automatically established and user has no need to configure it again.

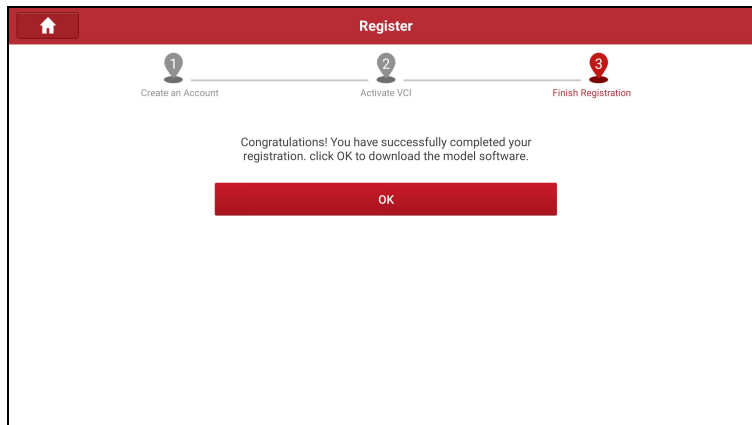

3. Finish Registration: Tap **OK** to navigate to the download page and download the diagnostic software.

On the download page, tap **Update** to start downloading. To pause downloading, tap **Stop**. Once download is complete, the system will install the software package automatically.

Note: When downloading the diagnostic software or checking for updates, make sure the tablet has a strong signal. It may take a long time to finish it, please be patient to wait.

B. If you have registered to be a member, input your name and password, and then tap the **Login** button to enter the main menu screen directly.

Note: The tablet has an auto-save function. Once the username and password are correctly entered, the system will automatically store it. After initial setup, it is no longer necessary to input the account information manually to log in.

C. If you forgot the password, tap **Retrieve password** and then follow on-screen instructions to set a new password.

3.2 Home Screen

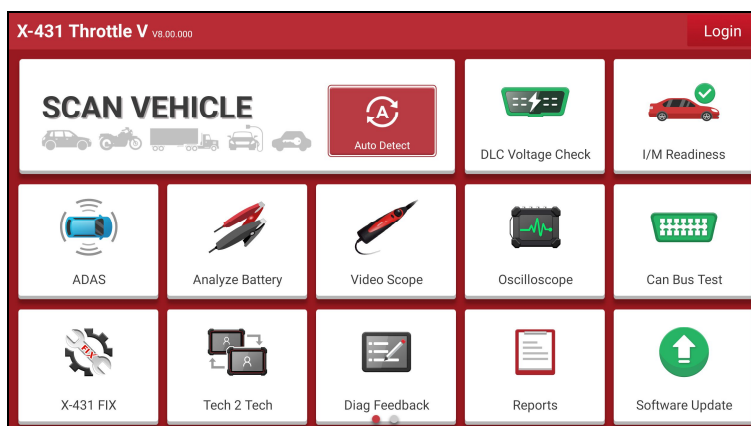

It mainly includes the following items:

Name	Description
Diagnose	Configure the tool as a professional tool. It includes two kinds of diagnosis methods: Smart Diagnose (Auto Detect) and Manual Diagnose (Scan Vehicle).
DLC Voltage Check	Perform a check of the vehicle's battery to ensure the system is operating within acceptable limits.
I/M Readiness	This function checks whether or not the various emissions-related systems on the vehicle are operating properly, and are ready for Inspection and Maintenance testing. It can also be used to check the Monitor Run Status, and to confirm if the repair of a car fault has been performed correctly.
ADAS	To perform the ADAS (Advanced Driver Assistance System) calibration operations. Refer to Chapter 8.1 for details.
Analyze Battery	To test whether vehicle's battery is good or not. Refer to Chapter 8.2 for details.
Video Scope	To check unseen or unreachable parts or components. Refer to Chapter 8.3 for details.
Oscilloscope	To determine vehicle electrical equipment and circuit trouble. Refer to Chapter 8.4 for details.
Can Bus Test	This function allows you to detect the voltage of the vehicle OBD II diagnostic socket pins and the supported protocol types to help technicians judge the OBD II diagnostic interface.
X-431 Fix	This function can be activated via X-431 Fix Data Access Activation Card. It allows you to access full instructions of passenger /heavy duty vehicles on how to fix and finish the repair job for found DTCs.
Tech 2 Tech	This function aims to help repair shops or technicians launch instant messaging and remote diagnosis, making the repair job getting fixed faster.
Diag. Feedback	This function allows you to feedback your diagnostic problems to us for analysis and troubleshooting.
Reports	This function is used to manage saved reports or recorded data.
Software Update	Update vehicle diagnostic software and APK.
Vehicle Coverage	Check which vehicle models are supported on the tool.
Sensor Simulator	To diagnose/simulate vehicle ECU sensor trouble. Refer to Chapter 8.5 for details.

LAUNCH

Multimeter	To measure the physical parameters such as voltage, resistance, frequency etc. Refer to Chapter 8.6 for details.
X-431 TSGUN	To perform all kinds of TPMS (Tire Pressure Monitoring System) operations. Refer to Chapter 8.7 for details.
Mall	This function enables you to renew the software subscription, and subscribe some extra software or service functions that are not integrated in the tool online.
X-431 Settings	Makes some system settings of diagnostic application.
File Manager	A file and application manager.
Android Settings	Quick access to the Settings module of Android operating system.
System Upgrade	Check for updates of system version.
Manual & Help	Includes Customer Service hotline, Training Videos, FAQ, Quick Start Guide and User Manual.
Web Repair Sites	Quick access to a lot of well-known professional repair sites.
Camera	This function allows you to take pictures or record videos with the built-in cameras.

4 Connections

4.1 Preparation

1. Switch the vehicle's ignition off.
2. Make sure that the ignition is turned off and vehicle battery voltage range is 11-14V or 18-30V.
3. Find DLC (Data Link Connector) location.

For passenger cars, the DLC is usually located 12 inches from the center of the instrument panel, under or around the driver's side for most vehicles. For some vehicles with special designs, the DLC location may vary.

For commercial vehicles, the DLC is always located in driver's cab.

For motorcycles, refer to the motorcycle's service manual for the location.

If the DLC cannot be found, refer to the vehicle's service manual for the location.

4. Turn the vehicle's ignition ON with engine OFF.
5. Now the tool is ready for diagnostics.

4.2 Vehicle Connection

The method used to connect the VCI device to a vehicle's DLC depends on the vehicle's configuration as follows:

For OBD II vehicles, use the included diagnostic cable (DB15F to HD15F data cable and HD15M to OBD16 adapter) to connect the VCI to the vehicle's DLC port.

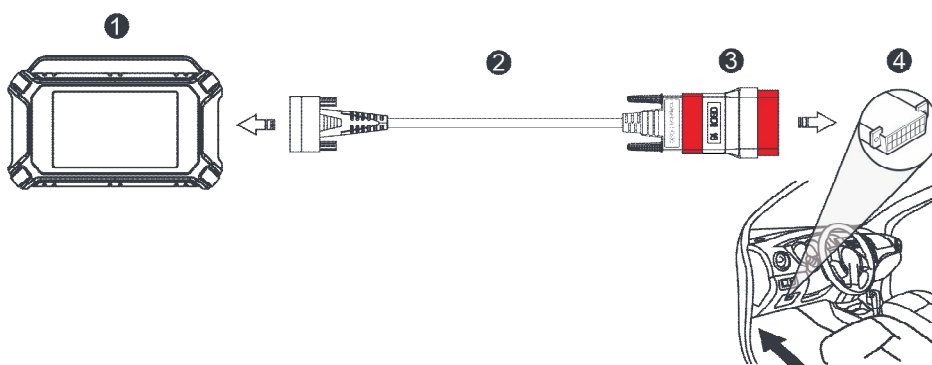

1. VCI
2. DB15F to HD15F data cable
3. HD15M to OBD16 adapter
4. Vehicle's DLC port

For non-OBDII vehicles, refer to the above figure to make connection.

1. Select the appropriate adapter according to the vehicle's DLC port type (4).
2. Loosen the captive screws of the DB15F to HD15F data cable (2) and disconnect the HD15M to OBD16 adapter (3) from the data cable.
3. Connect the data cable (2) with the target adapter (sold separately) on the above figure and tighten the screws. Other steps shall also apply.

If you choose to perform vehicle diagnosis via data cable, connect one end of the data cable into the VCI, and the other end into the data I/O port of the tablet.

4.3 Communication Setup

There are two kinds of ways available for the tablet to communicate with the VCI device: wireless and wired (USB).

After the user registration is successfully finished, the wireless communication between the tablet and the VCI device is

LAUNCH

automatically established and user has no need to configure it again.

The USB connection is a simple & quick way to establish communication between the tablet and the VCI. After properly connecting the data cable from the tablet to the VCI, the VCI navigation button at the bottom of the screen will be enabled indicating the USB connection is successful.

 Note: The USB connection provides the most stable and fastest communication. When all communication methods are applied at the same time, the tablet will use the wired communication as the default priority.

5 Diagnosis

The tool supports AutoDetect and manual selection covering OBD II diagnosis, full system diagnosis for most modern vehicles worldwide.

 Note: This function needs to work with New Energy Vehicle Diagnosis Add-on Kit (optional), which can be purchased from the authorized dealer.

5.1 Smart Diagnose (Auto Detect)

This function allows you to quickly decode the VIN (Vehicle Identification Number) information of the test vehicle without performing step-by-step manual menu selection.

 Notes:

- Before using this function, please make sure the VCI is properly connected to the vehicle's DLC port. For detailed connection, see Chapter 4.2.
- A stable network connection is required for this function.

Follow the steps below to proceed.

1. Tap **Auto Detect**, the following screen will appear.

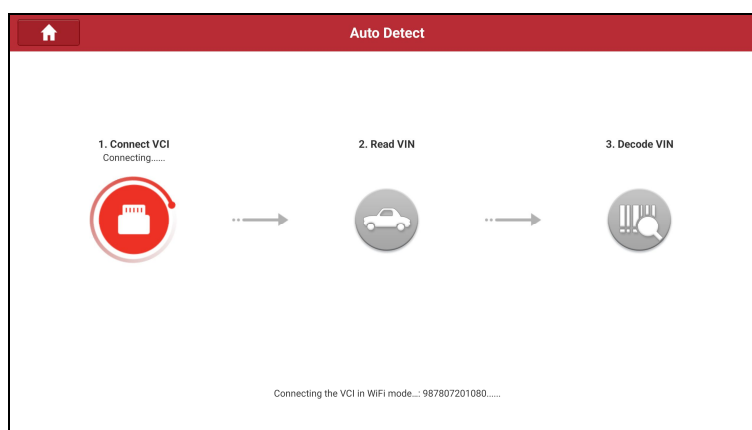

2. After pairing is complete, the tablet starts reading the vehicle VIN.

A. If the VIN can be decoded successfully, it will enter the following vehicle information page.

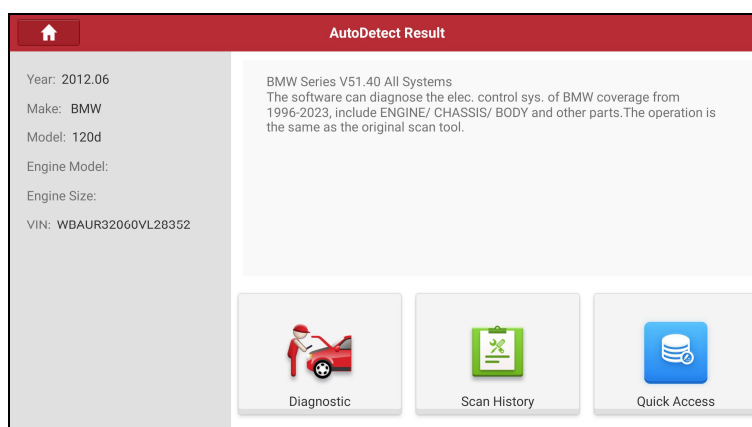

- Tap **Diagnostic** to start a new diagnostic session.
- Tap **Scan History** to view its historical repair record. If there are records available, it will be listed on the screen in sequence of date. If no records exist, the screen will show *No Record*.
- To perform other functions, tap **Quick access** to directly go to the diagnostic function selection screen. Choose the desired one to start a new diagnostic session.



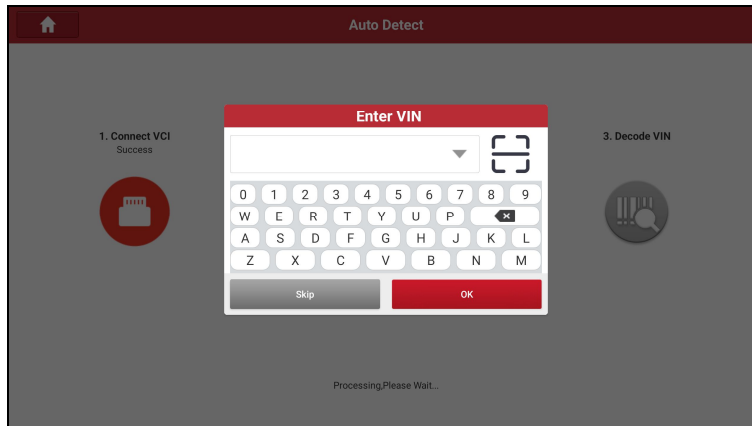

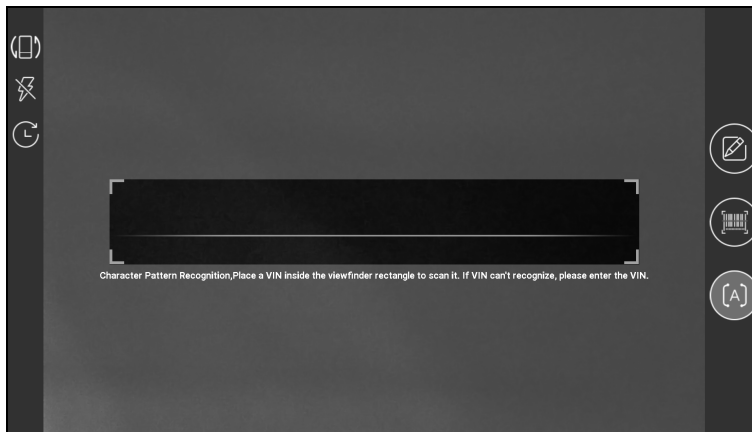

B. If the tablet failed to access the VIN information, the following screen will appear:



- Tap the input field to input directly, tap **OK**. If the VIN exists on the remote server, the system will enter the vehicle information screen.
- Tap  to launch the VIN recognition module.



Place the VIN inside the viewfinder rectangle to scan it. The most recognizable location for this number is in the top left corner on the vehicle's dashboard. Other locations include the driver's door or post, and the firewall under the hood.

- Tap  to switch the display mode of the screen.
- Tap  to turn the camera flash on.
- Tap  to choose it from the record list if the VIN of the vehicle has been scanned before.
- Tap  to input the VIN manually if the tablet has failed to identify the VIN of the vehicle.
- Tap  to scan the VIN barcode. If the VIN barcode cannot be recognized, please manually input the VIN.
- Tap  to scan the VIN character. If the VIN character cannot be recognized, please manually input the VIN.

 **Note:** In general, vehicle identification numbers are standardized - all contain 17 characters. VIN characters may be capital letters A through Z and numbers 1 through 0; however, the letters I, O and Q are never used in order to avoid mistakes of misreading. No signs or spaces are allowed in the VIN.

After scanning, the screen automatically displays the result.

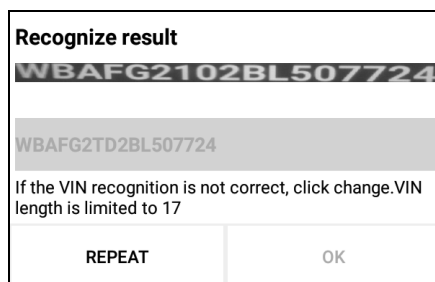

- If the VIN scanned is incorrect, tap the result field to modify it and then tap **OK**.
- To scan it again, tap **REPEAT**.

If the VIN can be decoded successfully, the system will enter the vehicle information screen.

5.2 Manual Diagnose (Scan Vehicle)

This function allows you to diagnose electronic control systems of single vehicle models by manually executing the menu-driven command.

Tap **Scan Vehicle**, the following screen will appear:

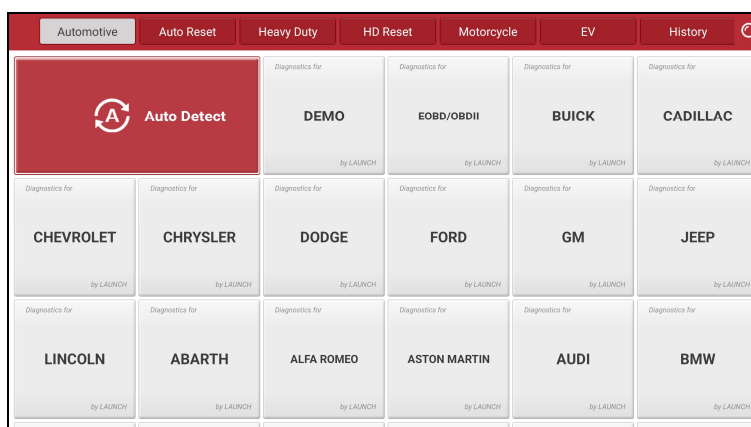

Tap **Automotive** to enter the passenger cars selection screen.

Tap **Auto Reset** to enter the reset function selection screen of passenger cars.

Tap **Heavy Duty** to enter the heavy duty vehicles selection screen.

Tap **HD Reset** to enter the reset function selection screen of heavy duty vehicles.

 Note: This function needs to work with HD Diagnosis Add-on Kit (optional), which can be purchased from the authorized dealer.

Tap **Motorcycle** to enter the motorcycles selection screen.

 Note: This function needs to work with Motorcycle Diagnosis Add-on Kit (optional), which can be purchased from the authorized dealer.

Tap **EV** to enter the electric cars selection screen.

 Note: This function needs to work with New Energy Vehicle Diagnosis Add-on Kit (optional), which can be purchased from the authorized dealer.

Tap **History** to enter historical diagnostic record screen.

2 approaches are provided for you to access the vehicle diagnostic software. Choose any one of the following ways:

1. Operations of Auto Detect are same as Intelligent Diagnose. Refer to Chapter 5.1 for details.
2. Tap a corresponding diagnostic software logo, and then follow the on-screen instruction to access the diagnostic software.

Take Demo (Version 15.54) as an example to demonstrate how to diagnose a vehicle.

- 1). Select diagnostic software version: Tap the **DEMO** to go to Step 2.

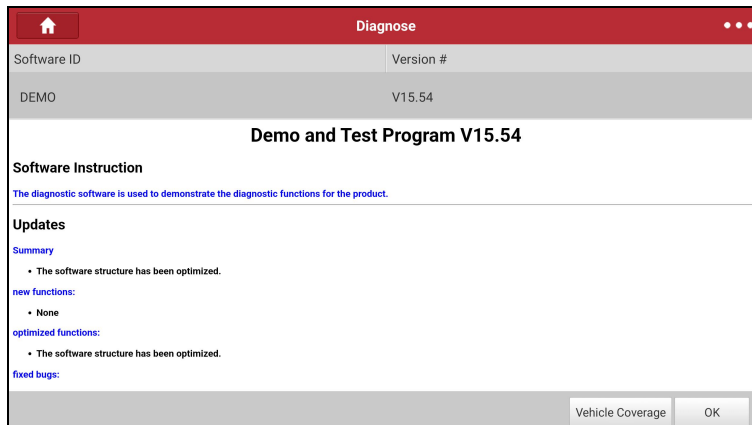

On-screen Buttons:

Vehicle Coverage: Tap to view the vehicle models that the current diagnostic software covers.

OK: Tap it to go to next step.

- 2). Select vehicle model. Here we take **TOYOTA** for example to demonstrate how to diagnose a vehicle.
- 3). Select the desired test item to proceed.

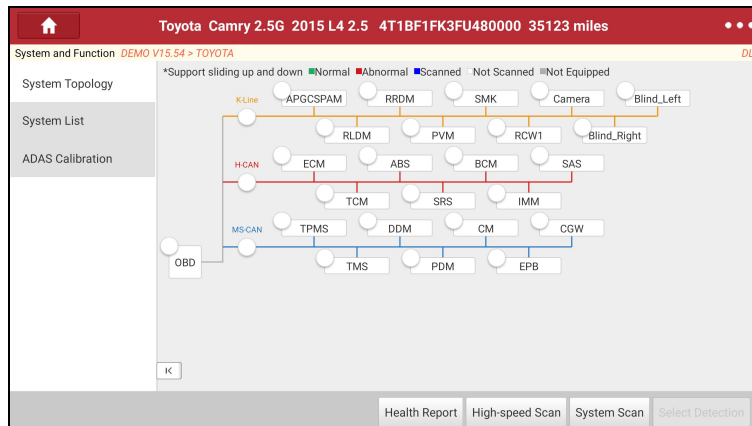

System Topology: Displays all available vehicle systems in form of topology structure.

System List: Displays all available vehicle systems in form of list.

ADAS Calibration: Performs ADAS calibration operations. It is extracted from the system list as a functional module and provides a quick access to ADAS system.

- While in System Topology mode, different highlight bars indicate different detection status.

On-screen Buttons:

Health Report: Tap to quickly access all the electronic control units of the vehicle and generate a detailed report about vehicle health. The tested systems malfunctioning are displayed in red with a number indicator displaying DTC quantity and the systems with functioning properly are displayed in green.

Warning: Diagnostic Trouble Codes or Fault Codes can be used to identify which engine systems or components that are malfunctioning. Never replace a part based only on the DTC definition. Retrieving and using DTCs for troubleshooting vehicle operation is only one part of an overall diagnostic strategy. Follow testing procedures (in vehicle’s service manual), instructions and flowcharts to confirm the locations of the problem.

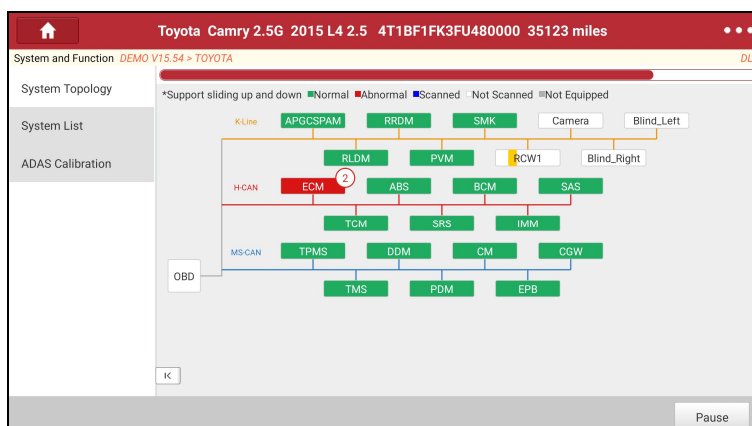

- **Report:** Tap to save the current data in text format. All reports are saved in **Reports -> Health Reports**.

Notes:

1. Diagnostic report is classified into two categories: Pre-Repair report and Post-Repair report. To facilitate the comparison of the pre-repair and post-repair reports and get accurate test result, please make sure you saved the right type of the diagnostic report.
 2. By default, the workshop information is blank. You can configure and revise it from **X-431 Settings -> Account & Shop Information -> Shop Information**. After you configured the information, it will be automatically generated every time the diagnostic report is saved. All vehicle and workshop information will be appended as a tag on the diagnostic report, which allows you to easily retrieve the desired report while performing Filter function of Diagnostic Report.
- **Compare Results:** Tap to select the pre-repair report to compare. By comparison of the pre- and post- repair reports, you can easily identify which DTCs are cleared and which remain unfixed.

DTC	Current	History
Engine		
P2118 Throttle Actuator 'A' Control Motor Range/Performance	Cleared	Found
P0504 Brake Switch A/B Correlation	Cleared	Found
Radar Cruise 1		
C1521 CAN bus:Signal Failure	Cleared	Found

Note: Before performing this function, please make sure that: 1) You have saved a pre-repair report of the currently tested vehicle; and 2) You have already made some repairs and service and cleared the DTCs after the pre-repair reported is generated. Otherwise, no differences exist between the pre- and post- repair reports.

- **Diagnostic Plan:** Figures out the diagnostic plan and repair solutions for the detected DTCs.
- **Clear DTCs:** Tap to clear the existing diagnostic trouble codes.

Note: Clearing DTCs does not fix the problem(s) that caused the code(s) to be set. If proper repairs to correct the problem that caused the code(s) to be set are not made, the code(s) will appear again and the check engine light will illuminate as soon as the problem that cause the DTC to set manifests itself.

High-speed Scan: Tap to simultaneously scan all vehicle systems and generate a detailed report about vehicle health. This function runs faster than smart detection.

System Scan: Tap to scan which systems are installed on the vehicle.

Select Detection: Select certain system manually to start scanning.

- While in System List mode, the following screen will appear.

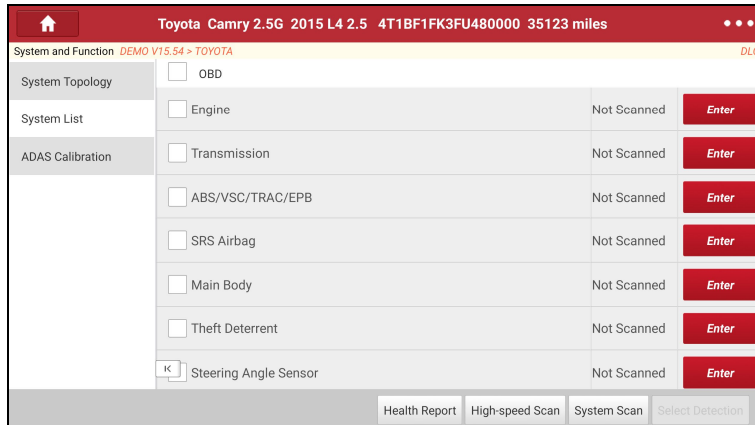

- **Enter:** Select certain system, and tap this button to enter the diagnostic function selection screen.

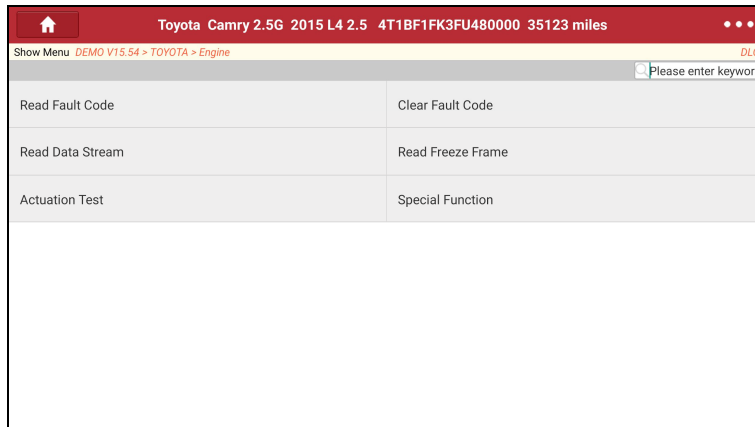

In general, the diagnostic functions vary with different vehicle models. It mainly includes the following options:

A. Read Fault Code

This function displays the detailed information of DTC records retrieved from the vehicle’s control system.

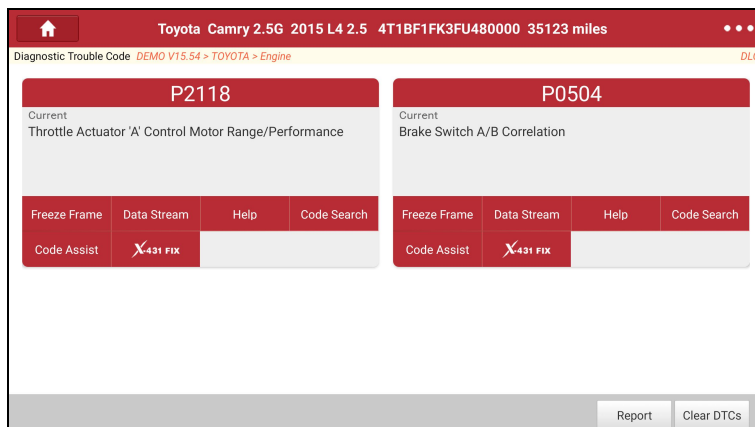

On-screen Buttons:

Freeze Frame: Tap it to view the snapshot of critical parameter values at the time the DTC is set.

Help: Tap to view the help information.

Code Search: Tap it to search for more information about the current DTC online.

Code Assist: Tap it to check more details on the current DTC from the Code Assist.

X-431 Fix: Tap it to retrieve this DTC from the X-431 Fix auto repair database.

Report: To save the current data in text format. All reports are saved in **Reports -> Health Reports**.

Clear DTCs: Tap to clear the existing diagnostic trouble codes.

B. Clear Fault Code

This option can erase the codes from the vehicle. Before the operation, please make sure the vehicle's ignition key is in the ON position with the engine off.

 Note: After clearing, you should retrieve trouble codes once more or turn ignition on and retrieve codes again. If there are still some trouble codes in the system, please troubleshoot the code using a factory diagnosis guide, then clear the code and recheck.

C. Read Data Stream

This option retrieves and displays live data and parameters from the vehicle's ECU.

 Caution: If you must drive the vehicle in order to perform a troubleshooting procedure, ALWAYS have a second person help you. Trying to drive and operate the diagnostic tool at the same time is dangerous, and could cause a serious traffic accident.

 Note: The real time (Live Data) vehicle operating information (values/status) that the on-board computer supplies to the tool for each sensor, actuator, switch, etc. is called Parameter Identification Data (PID).



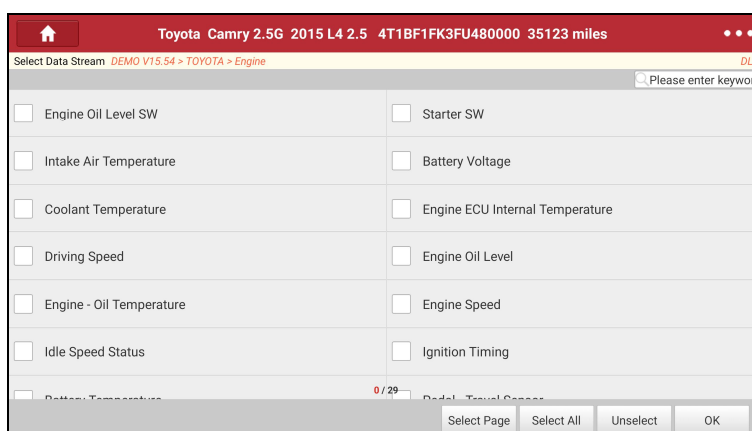

Tap **Read Data Stream**, the following screen will appear:

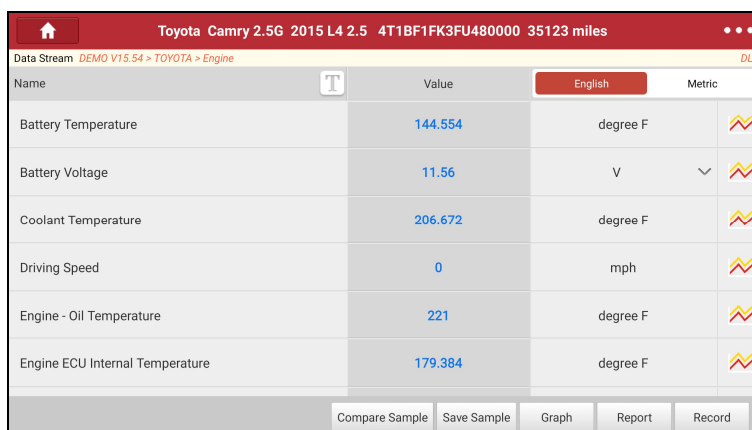

After selecting the desired items, tap **OK** to enter the data stream reading page.



 Notes:

1. Tap  to set the display style.  indicates sticky top. If it is tapped, it will change into . On the data stream display screen, the data stream item with  will be shown on the top of the selected data stream list. To remove it from the top of the list, just tap it again. B indicates this item will be displayed in **Bold**. A indicates this item will be displayed in Red.
2. Tap **English** or **Metric** to switch the measurement unit.
3. If the value of the data stream item is out of the range of the standard (reference) value, the whole line will display in red. If it complies with the reference value, it displays in blue (normal mode).

There are 3 types of display modes available for data viewing, allowing you to view various types of parameters in the most suitable way.

- Value – this is the default mode which displays the parameters in texts and shows in list format.
- Graph – displays the parameters in waveform graphs.
- Combine – this option is mostly used in graph merge status for data comparison. In this case, different items are

LAUNCH

marked in different colors.

On-screen Buttons:

: Tap it to view the live waveform of current data stream item.

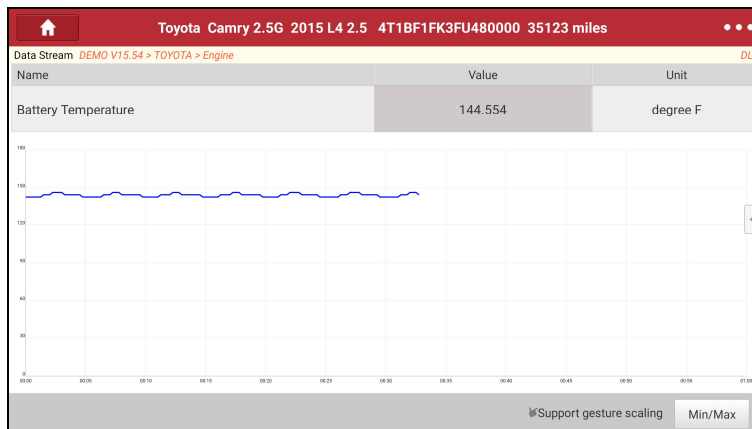

Graph: Tap it to view the waveform of the selected data streams. Tap  on the edge of the screen to customize the target data streams for displaying.

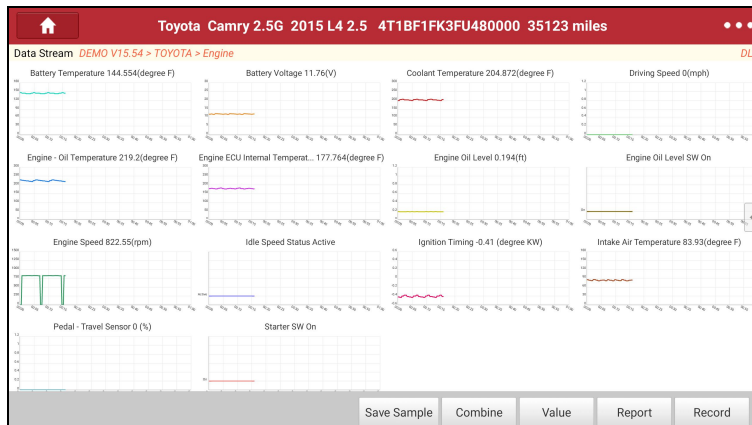

Compare Sample: Tap it to select the sample data stream file, the values you customized and saved in process of data stream sampling will be imported into the **Standard Range** column for your comparison.



 **Note:** Before executing this function, you have to sample the values of data stream items and save it as a sample data stream file.

Report: To save the current data in text format. All reports are saved in **Reports -> Health Reports**.

Record: Tap to start recording diagnostic data. Recorded live data can serve as valuable information to help you in troubleshooting of vehicle problems. All recorded files are stored in **Reports -> Recorded Data**.

Help: Tap to view the help information.

Save Sample: This item enables you to customize the standard range of live data stream items and save it as sample file. Each time you run the data stream items, you can call out the corresponding sample data to overwrite the current standard range.

Tap it to start recording the sample data ( **Note:** Only data stream items with units will be recorded). Once recording is complete, tap  to stop it and navigate to the data modification screen.

Name	Min Value	Max Value	Unit
Battery Temperature	61.52	X 63.54	degree C
Battery Voltage	11.56	X 11.96	V
Coolant Temperature	93.04	X 97.04	degree C
Driving Speed	0.0	X 0.0	km/h
Engine - Oil Temperature	104.0	X 109.0	degree C
Engine ECU Internal Temperature	80.78	X 83.78	degree C

Tap the value to change it. After modifying all desired items, tap **Save** to save it. All data stream files are stored in **X-431 Settings -> Manage Software Data -> Sample**.

D. Read Freeze Frame

This option takes the snapshot of the operating conditions when a vehicle fault occurs.

E. Actuation Test

This option is used to access vehicle-specific subsystem and component tests. Available test vary by vehicle manufacturer, year, and model.

During the actuation test, the tablet outputs commands to the ECU in order to drive the actuators, and then determines the integrity of the system or parts by reading the ECU data, or by monitoring the operation of the actuators, such as switching a injector between two operating states.

F. Special Functions

This option offers coding, reset, relearn and more service functions, to help vehicles get back to functional status after repair or replacement. Available tests vary by vehicle manufacturer, year, and model.

5.3 Remote Diagnose (Tech 2 Tech)

This option aims to help repair shops or technicians launch instant messaging and remote diagnosis, making the repair job getting fixed faster.

Tap **Tech 2 Tech** on the home screen to enter the following screen.

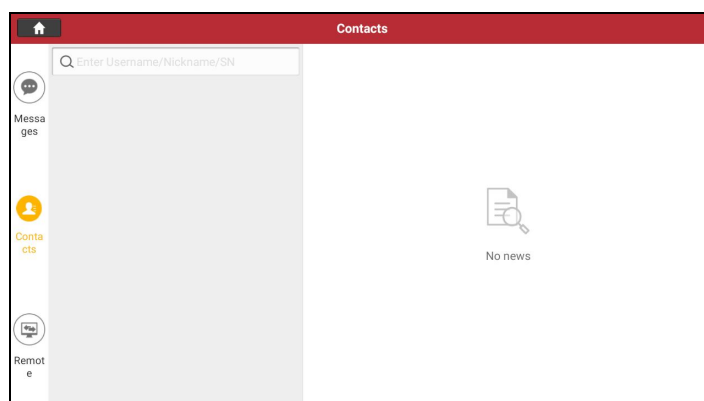

Messages tab: Once an incoming message reaches, a red dot will appear on the upper right corner of the tab.

Contacts tab: Tap to enter the friend list.

Remote tab: Tap to slide the switch to ON, the tool keeps online and becomes accessible on the web client. In this case, inform the technician of your product S/N, and he/she will control your device remotely.

Search bar: Directly input the registered username of the tool to start searching, and then tap the desired one to add it into your friend list.

Home button: Tap it to navigate to the home screen.

5.3.1 Adding Friends

Tap **Contacts**. By default it appears blank.

In the search bar, input the partner’s username and tap **Search** to start searching.

The partner must be the users who have registered specific diagnostic tools. They may be the following roles: Workshop / Technician / golo user.

Once the result matches the keyword, the following screen will appear:

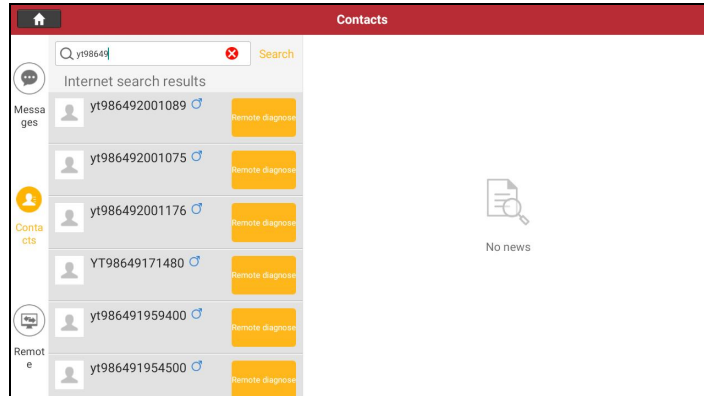

To launch the remote diagnostics directly, tap **Remote Diagnose** to invite a remote control or request control remote device.

To view the partner’s detailed information, tap  to add him/her as your friend. After the partner agreed your request, you will receive a piece of verification information and he/she will automatically be listed in the Contacts tab.

5.3.2 Start Instant Messaging

The I/M (Instant Messaging) function is open to all users who had the diagnostic tool equipped with this module.

A. If you do not add the partner as your friend, tap  to enter the following screen:

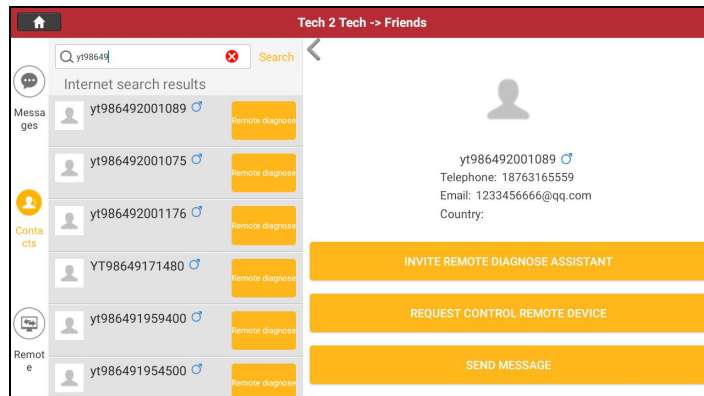

Tap **Send Message** to enter the dialog mode.

B. If you have added the partner into the Contacts, directly tap the desired fellow technician’s photo (avatar) to start a conversation.

Tap the input field and use the on-screen keyboard to enter the text, and tap **Send**.

Here you can send voice messages and emoji. Tap + to call out more function options.

File: Choose diagnostic reports or local files to send.

Picture: Choose screenshots or pictures to send.

Remote Diagnose: To start a remote diagnostic session.

Camera: Open camera to take pictures.

Tap **Clear** to delete all the partner’s dialog logs.

5.3.3 Launch Remote Diagnosis (Scanner-To-Scanner)

The tool is allowed to initiate remote diagnosis with other diagnostic tools, which are equipped with this module. On the function option selection screen, tap **Tech 2 Tech**, the following pull-down menu will appear:

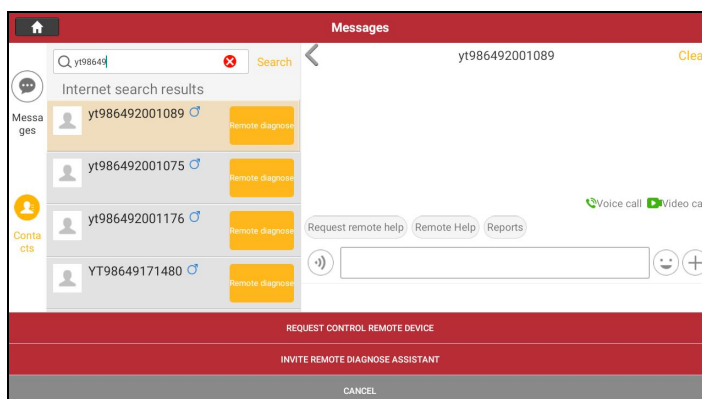

These options are defined as follows:

Actions	Results
Request control remote device	<p>Request to control the partner’s device remotely to help him diagnose the vehicle.</p> <p> Note: Once vehicle diagnosis is complete, a report will be created. Input your comments on this report, and then tap Send Report to send it to the partner.</p> <pre> graph TD A[Tap "Request control remote device"] --> B[Wait for partner's confirmation] B --> C[Start connecting after request confirmed] C --> D[Start Diagnosis] D --> E[Generate diagnostic report] </pre>
Invite remote diagnostic assistant	Use this option to invite a technician to perform a remote control on your tool.

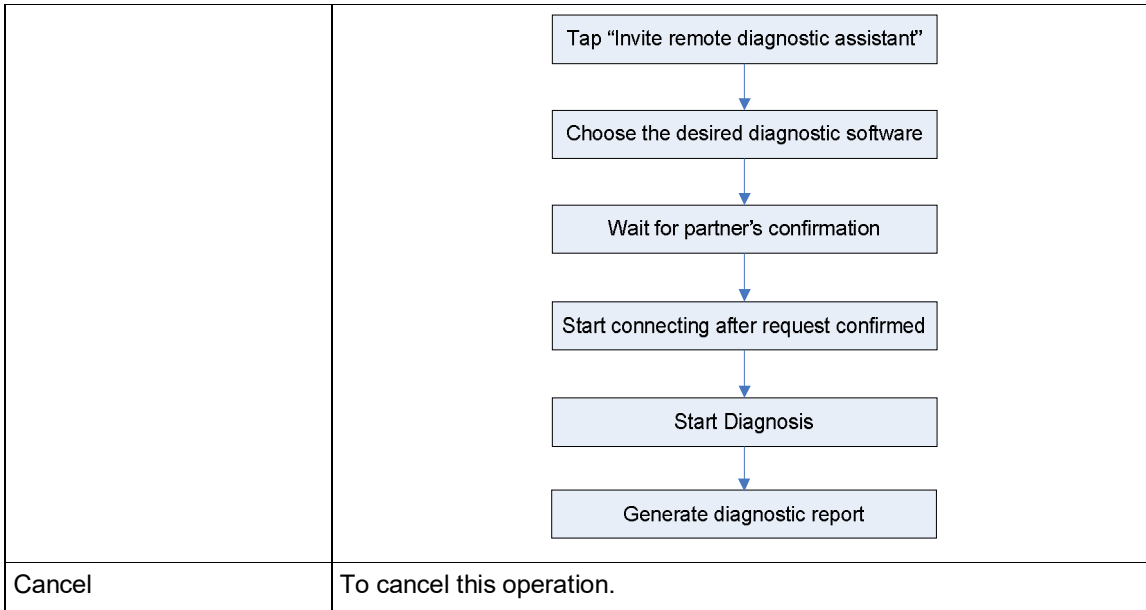

5.3.4 Launch Remote Diagnosis (Based on Web-based Remote Diagnostics Platform)

Except that the remote diagnosis can be done between different Diesel’s diagnostic tools that come loaded with the Tech 2 Tech module, user can also ask for remote control or provide remote assistant on Web-based remote diagnostics platform.

Tap **Remote**, the following screen will appear:

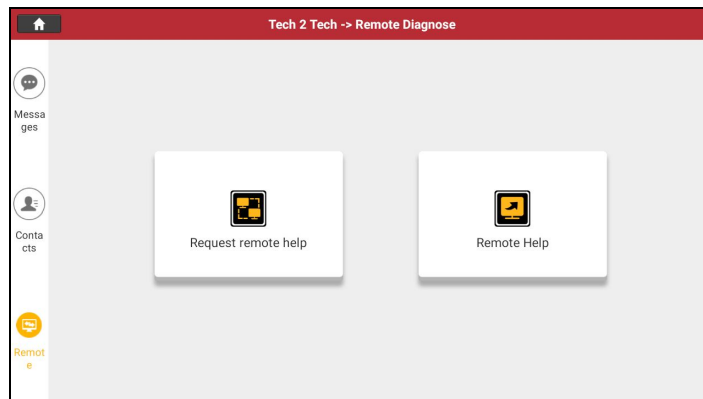

1. Request remote help

1). Tap **Request remote help**, the following screen will appear:

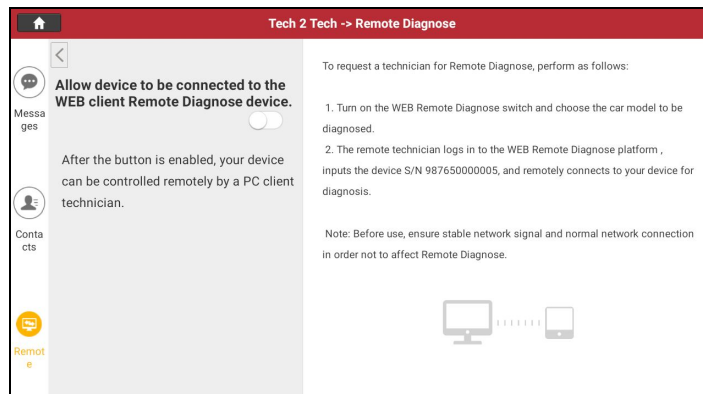

2). Slide the switch to ON so that the partner can remotely control your tool while using the remote diagnostics service platform.

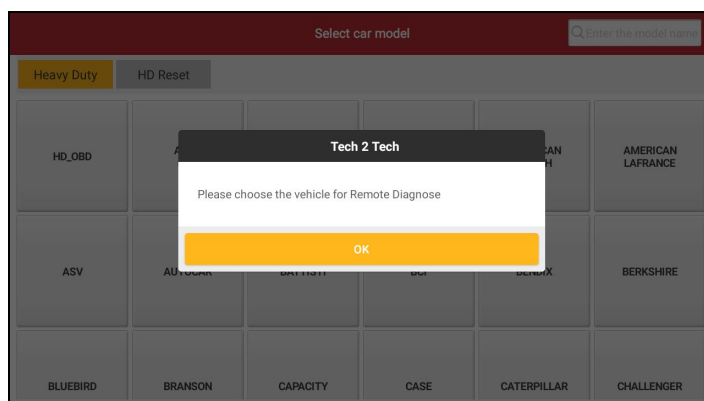

3). Tap **OK** and choose the desired vehicle model. The following screen will appear:

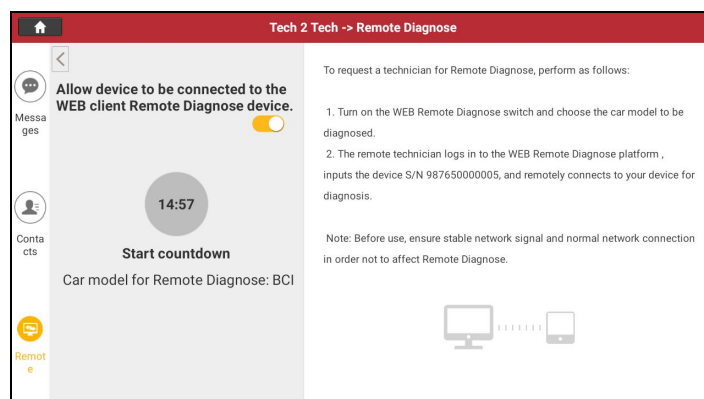

4). Notify the remote technician of the web remote diagnostics platform web link (<http://remote.x431.com>) and ask him/her to log in to the web remote diagnostics platform.

Note: Before processing remote diagnosis, please make sure the tool is properly connected to the vehicle.

5). After successfully logging in, input the S/N of your device and now your device will be controlled remotely by the partner technician.

The operations in remote diagnosis are same as those in local diagnose. Once the session is complete, a remote diagnostic report will be automatically generated.

2. Provide remote help

1). Tap **Remote**, the following screen will appear:

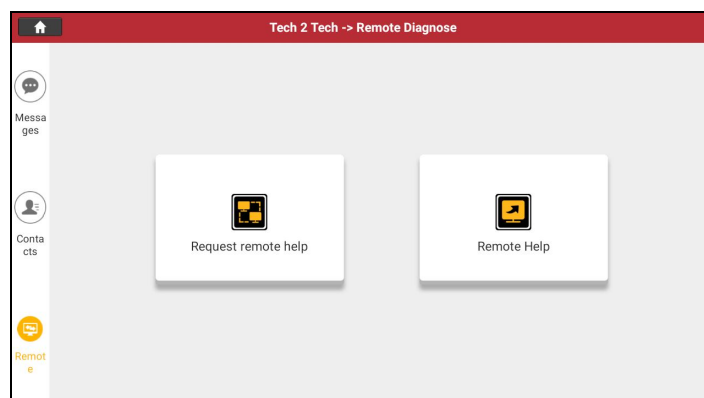

2). Tap **Remote Help**, the following screen will appear.

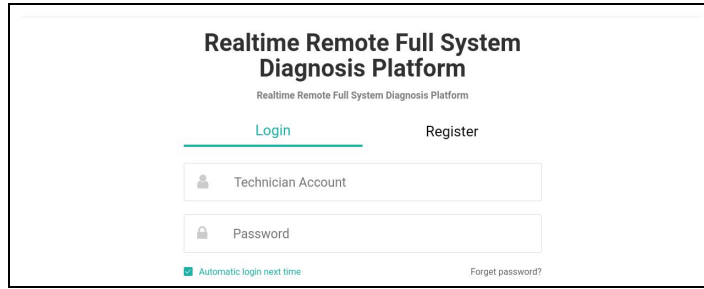

- 3). Enter your valid technician account and password to log in to the web remote diagnostics platform.
- 4). After successfully logging in, input the S/N of your partner’s scanner and now you can control the partner’s scanner remotely.

5.4 I/M Readiness

This function checks whether or not the various emissions-related systems on the vehicle are operating properly, and are ready for Inspection and Maintenance testing.

It can also be used to check the Monitor Run Status, and to confirm if the repair of a car fault has been performed correctly.

Tap **I/M Readiness** on the home screen to start checking. After checking all I/M readiness status, the screen will output the result:

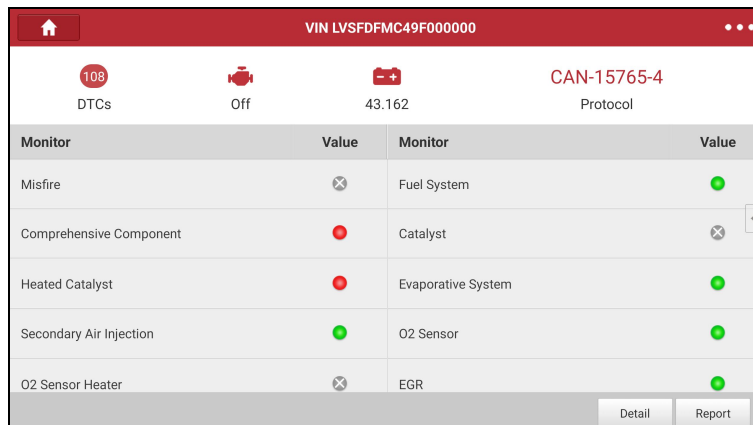

Note: ⊗ means not available on this vehicle, ● means incomplete or not ready, ● means Completed or Monitor Ok.

5.5 Diagnostic History

This function allows a quick access to previously tested vehicle records. Testing can be resumed from the previous operation without starting from scratch.

Tap **Scan Vehicle -> History**, all diagnostic records will be listed on the screen in date sequence.

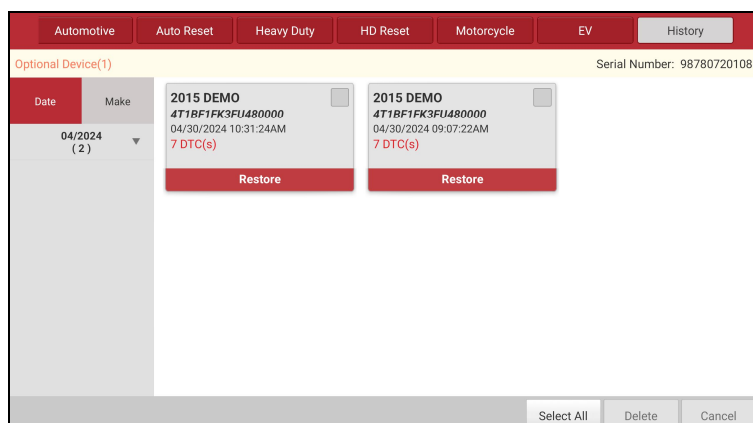

5.6 Diag. Feedback

This function enables you to send the feedback of your diagnostic problems to us for further analysis and troubleshooting.

Tap **Diag. Feedback** on the home screen. There are 3 options available:

- 1). Feedback: To send a tested vehicle diagnostic feedback.
- 2). History: To view all diagnostic feedback records.
- 3). Offline list: To view all diagnostic logs that have failed to be submitted, which will be uploaded again to the remote server automatically once the tablet gets the stable network.

6 Service Function (Reset)

It offers coding, reset, relearn and more service functions, to help vehicles get back to functional status after repair or replacement. Available tests vary by vehicle manufacturer, year, and model.

Due to continuing improvements, available service functions are subject to change without prior written notice. To enjoy more service functions, you are suggested to check for updates on a regular basis.

Generally there are two methods available to perform the reset procedures: Manual reset or Auto reset. Auto reset follows the principle of sending command from the tool to vehicle's ECU to do resetting. While using manual reset, users just follow the on-screen instructions to select appropriate execution options, enter correct data or values, and perform necessary actions, the system will guide you through the complete performance for various service operations.

Tap **Scan Vehicle -> Auto Reset**. Choose the desired service function and then follow the on-screen instructions to finish the procedure.

7 Software Update

This module enables you to update the diagnostic software & App and frequently used software.

7.1 Update Diagnostic Software & APP

Go to **Software Update** on the home screen and tap the **Downloaded** tab.

The **Available** tab displays a list of software that can be updated. Under it, all software is categorized into three kinds:

- **Common software:** mainly includes some common apps that are associated with the diagnostic app. The software of this kind always stays at the top of the list, which can be deselected manually (excluding the system app, such as firmware and ECU aid).
- **Frequently used vehicle software:** refers to the diagnostic software that is frequently used, including the vehicle diagnostic software and Reset software. It is generally displayed following the **Common software** list.
- **Other vehicle software:** refers to the diagnostic software that is rarely used or never used. It is generally displayed following the **Frequently used software** list.

- 1). If the user does not download any diagnostic software during the sign-up process, all diagnostic software is selected by default. Tap **Update** to start downloading.
- 2). If the user downloaded all/some vehicle software during the sign-up process and had it serviced for a long period of time, only the frequently used software is selected. Tap **Update** to start downloading. Other vehicle software that is rarely used will also be listed under the **Available** tab, but it is not selected at default.

Vehicle	Current Version	Update Version	Size	What's new
<input checked="" type="checkbox"/> CAN BOX Firmware upgrade Program		V21.69	171.8 K	Software optimization and update
<input checked="" type="checkbox"/> DOWNLOADBIN_X431PADIX		V25.15	151.0 K	Software optimization and update
<input checked="" type="checkbox"/> SmartLink_C_System_Update_File		V1.0.5.2.10.69	308.3 M	Software optimization and update
<input checked="" type="checkbox"/> SmartLink_C_Update_File		V10.75	42.0 M	Software optimization and update
<input checked="" type="checkbox"/> VINSKAN Service		V11.02	59.6 M	Software optimization and update
<input checked="" type="checkbox"/> BST360_APP		V1.01.016	17.8 M	Software optimization and update

To download certain software that is not frequently used, check the box before the vehicle model. Tap **Update** to start downloading.

Once download is finished, the software packages will be installed automatically.

7.2 Update Frequently Used software

If the user only intends to update the frequently used software, go to Software Update and tap the **Downloaded** tab.

Tap **Update** to start downloading. Once download is finished, the software packages will be installed automatically.

7.3 Renew Subscription

If the software subscription is due or expires, the system will prompt you to renew your subscription.

Tap **Renewal** on the bottom of the screen to enter the **Mail** to renew the subscription.

8 Toolbox

Each module consists of two parts: hardware and app. These modules cannot work properly on the tablet, which need to work with the specific compatible hardware (sold separately). For detailed operations, refer to the User Manual of each module.

8.1 ADAS (Calibration)

This module enables you to effectively and accurately calibrate a wide range of camera-based & radar-based driver assistance systems, e.g. the front camera for the lane departure warning system, the radar sensor for the ACC (Adaptive Cruise Control) or the camera for adaptive headlights. It needs to work with the specific ADAS calibration tool (sold separately).

For more details, please refer to the User Manual included with the module.

8.2 Analyze Battery (BST360)

This module allows you to fix battery detection faster and easier. It needs to work with the specific Bluetooth battery tester (sold separately).

For more details, please refer to the User Manual included with the module.

8.3 Video Scope

This module allows you to check those unseen parts of engine, fuel tank, and braking system etc. It needs to work with the compatible Videoscope (sold separately).

For more details, please refer to the User Manual included with the module.

8.4 Oscilloscope

This module can make the auto repair technician quickly judge the faults on automotive electronic equipment and wiring. It needs to work with the specific Scopebox (sold separately).

For more details, please refer to the User Manual included with the module.

8.5 Sensor Simulator

This module is specially designed to diagnose and simulator vehicle sensor faults quickly and conveniently. It needs to work with the compatible S2-2 Sensorbox (sold separately).

For more details, please refer to the User Manual included with the module.

8.6 Multimeter

This module allows you to measure the physical parameters such as voltage, resistance, frequency etc. It utilizes the same hardware as the S2-2 Sensorbox.

For more details, please refer to the User Manual included with the S2-2 Sensorbox.

8.7 X-431 TSGUN (TPMS)

This module allows you to configure the tablet as TPMS (Tire Pressure Monitoring System) activation & diagnostic tool, which provides the ability to trigger TPMS sensor, program TPMS sensor, perform the relearning procedure. It needs to work with the compatible TSGUN device (sold separately).

For more details, please refer to the User Manual included with the module.

9 Reports

This function allows you to manage saved reports and diagnostic record.

Tap **Reports** on the home screen, there are 5 options available:

1. Health Reports

This module stores all diagnostic reports generated in process of vehicle diagnosis.

2. ADAS Reports

This module lists all ADAS calibration reports generated in process of ADAS calibration.

3. Remote Reports

This module lists all diagnostic reports generated in process of remote diagnostics.

4. ROXIE Reports

This module stores all vehicle inspection reports generated by the ROXIE W device that has been bound to the tool.

5. Recorded Data

This module stores all recorded data when running parameters or waveform graphs.

10 X-431 Settings

This function allows users to manage personal information, VCI and diagnostic data.

10.1 General

10.1.1 Units

The option can set the measurement unit. Metric System and English System are available.

10.1.2 Expiration Reminder

This option can set whether to push expiration reminder when the software is due or expires.

10.1.3 Diagnostic Software Auto Update

This option can turn on/off the automatic diagnostic software update function. If set as ON, the system will automatically update the available diagnostic software when the tablet has a network connection and a newer version is detected.

10.1.4 Diagnostic Application Auto Update

This option can set whether to update the available diagnostic application automatically when the scan tool has stable Wi-Fi signal.

10.1.5 Display shop information on reports

This option can set whether display shop information on every report.

10.1.6 Aggregated report service

This option can set whether to enable the report combination service.

10.2 VCI

If several VCI devices are activated on this tool, a list of VCI devices will be displayed on the screen.

Once you choose the device that belongs to other account, you have to log out, and then input the right account to continue.

- If the current VCI comes across communication failure, tap **Firmware Fix** to update and fix the diagnostic firmware. During fixing, please do not cut power or switch to other interfaces.
- If you skipped the Activate VCI step in process of sign-up, tap **Activate VCI**. Input the Serial Number and Activation Code (can be found from the included Password Envelope), and then tap **Activate** to activate it.

 Note: please be sure to keep the VCI device powered on while performing the operation.

10.3 VCI Management

This function allows you to set the communication method of the diagnostic tablet and VCI.

 Note: The USB connection provides the most stable and fastest communication. When all communication methods are applied at the same time, the tablet will use the wired communication as the default priority.

10.4 Account & Shop Information

10.4.1 Profile

Use this option to configure personal information.

10.4.2 Shop Information

This option lets you set your shop information. It mainly includes Workshop, Address and Telephone etc.

After you saved the information, it will be entered automatically every time you save the diagnostic report.

10.4.3 Technician

This feature enables you to create a technician list and assign a technician when saving diagnostic reports.

10.4.4 Change Password

This feature allows you to modify your login password.

10.4.5 Log Out

To logout the current user ID, tap **Log Out**.

To login the system again, tap **Login**.

10.5 Manage Subscriptions

This function allows you to check the expiration date of product configuration and repair database, and renew the subscription.

10.6 Display

10.6.1 Icon size

This feature allows you to set the size of the diagnostic software icon according to your preference.

Drag the slider to different size and the system will display the corresponding effect.

10.6.2 Color Theme

This feature enables you to set color theme of the diagnostic application to your preference.

10.6.3 Software display

This feature enables you to set display mode of the diagnostic software to your preference.

10.7 Manage Software Data

10.7.1 Hide & Remove Software

This feature allows you to hide/clear the diagnostic software that is not frequently used.

 Note: Removing software may completely delete the software from the tablet. If some software is not used and the tablet runs out of space, you can use this feature to remove it. To re-download it, go to **Software Update -> Available**.

10.7.2 Backup

This feature lets you back up the important data to external storage device.

10.7.3 Restore

This feature lets you restore the important data from external storage device.

10.7.4 Clear Diagnostic Application Cache

This feature is used to clear the App cache.

After clearing cache, the system will restart the App.

10.7.5 Sample

This feature allows you to manage the recorded data stream sample files.

10.8 Printer set

This option is designed to establish a wireless connection between the tablet and the Wi-Fi printer while performing printing operations.

The App is compatible with the **LAUNCH Wi-Fi Printer** (sold separately) and **System** (external printer).

LAUNCH

For LAUNCH Wi-Fi printer, refer to the User Manual included with the Wi-Fi printer to configure the printer settings.

For other Wi-Fi printers,

Before printing, make sure the following conditions are met:

- The Wi-Fi printer is powered on and working normally.
- The print service plug-in associated with the printer is already installed on the tablet (Go to Google Play or use the Browser to download and install it).

Follow the steps below to proceed:

1. Set the default printer as **System**.
2. Set the Wi-Fi switch to Off.
3. On the report details page, tap **Print**.

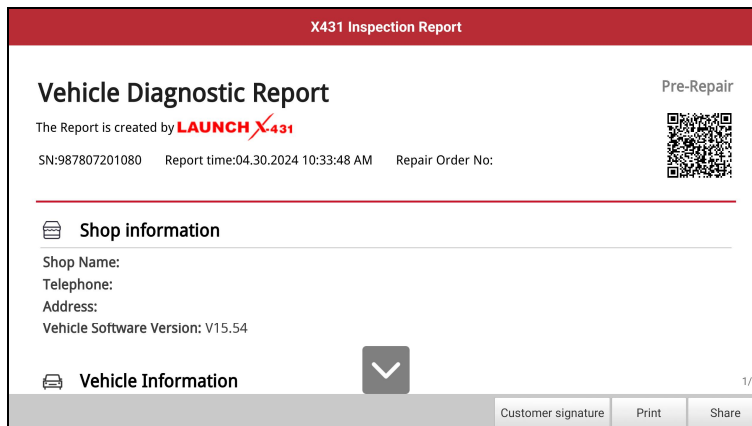

4. Touch ▼ next to **Select a printer** on the upper left corner of the screen.

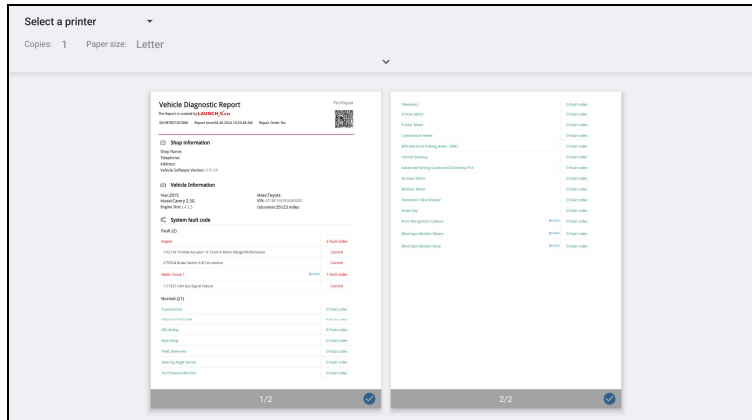

5. Select **All Printers** -> **Add printer** and enable the installed printer service, the system starts searching for all available Wi-Fi printers of the brand.

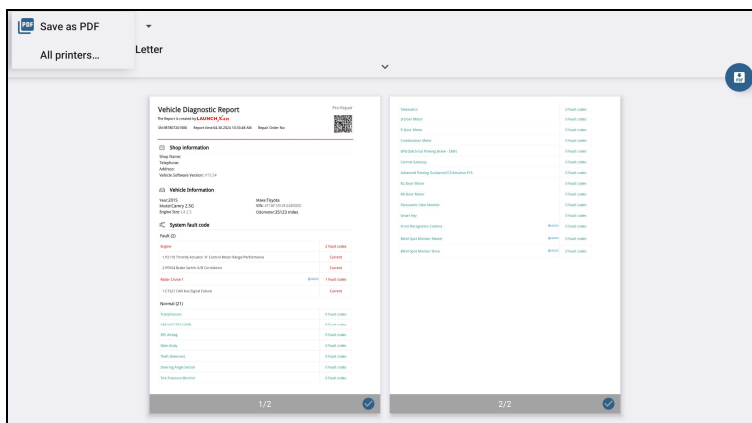

6. Select the desired Wi-Fi printer from the list. If the chosen Wi-Fi printer hotspot is open, the tablet can connect it directly. If it is encrypted, a password may be required. Refer to the Wi-Fi printer user manual to get the default password.
7. Now the printer is ready for printing.
8. Alternatively, you can also choose **Save as PDF** to save the current diagnostic report as a PDF file for later printing.

10.9 About

The software version information, Service Agreement and Privacy Policy are included.

11 J2534 Reprogramming Using SmartLink C

Reprogramming is often the only solution for problems ranging from driveability and loss of power to poor fuel economy and emissions related issues. SmartLink C makes it easy. The SmartLink C is a communication interface designed to support J2534 specifications for ECU reprogramming.

Except that the SmartLink C V3.0 can act as a VCI device, it also can be used as a J2534 PassThru device, working together with the PC installed with the OEM diagnostic software to perform the J2534 reprogramming. In this case, the PC needs to install with the LAUNCH's J2534 tool, which can be downloaded from the official website <https://en.cnlaunch.com>.

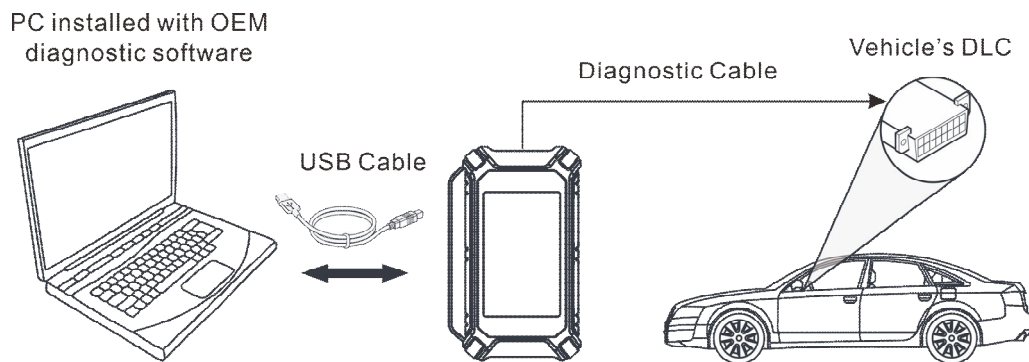

12 FAQ

1. How to save power?

1. Please turn off the screen while the tool keeps idle.
2. Set a shorter standby time.
3. Decrease the brightness of the screen.
4. If WLAN connection is not required, please turn it off.

2. Communication error with vehicle ECU?

Please confirm:

1. Whether the VCI is correctly connected.
2. Whether ignition switch is ON.
3. If all checks are normal, send vehicle year, make, model and VIN number to us using Feedback feature.

3. Failed to enter into vehicle ECU system?

Please confirm:

1. Whether the vehicle is equipped with this system.
2. Whether the VCI is correctly connected.
3. Whether ignition switch is ON.
4. If all checks are normal, send vehicle year, make, model and VIN number to us using Feedback feature.

4. What to do if the language of vehicle diagnostic software does not match the system language?

English is the default system language of the tool. After the system language is set to the preference language, please go to the update center to download the vehicle diagnostic software of the corresponding language.

If the downloaded diagnostic software is still displayed in English, it indicates that the software of the current language is under development.

5. How to retrieve the login password?

Please follow below steps to proceed in case you forgot the login password:

1. Tap the application icon on the home screen to launch it.
2. Tap the **Login** button on the upper right corner of the screen.
3. Tap **Retrieve password**.
4. Input product S/N and follow the on-screen prompts to retrieve the password.

Warranty

THIS WARRANTY IS EXPRESSLY LIMITED TO PERSONS WHO PURCHASE LAUNCH PRODUCTS FOR PURPOSES OF RESALE OR USE IN THE ORDINARY COURSE OF THE BUYER'S BUSINESS.

LAUNCH electronic product is warranted against defects in materials and workmanship for one year from date of delivery to the user.

This warranty does not cover any part that has been abused, altered, used for a purpose other than for which it was intended, or used in a manner inconsistent with instructions regarding use. The exclusive remedy for any automotive meter found to be defective is repair or replacement, and LAUNCH shall not be liable for any consequential or incidental damages.

Final determination of defects shall be made by LAUNCH in accordance with procedures established by LAUNCH. No agent, employee, or representative of LAUNCH has any authority to bind LAUNCH to any affirmation, representation, or warranty concerning LAUNCH automotive meters, except as stated herein.

Disclaimer

The above warranty is in lieu of any other warranty, expressed or implied, including any warranty of merchantability or fitness for a particular purpose.

Purchase Order

Replaceable and optional parts can be ordered directly from your LAUNCH authorized tool supplier. Your order should include the following information:

- Order quantity
- Part number
- Part name

Customer Service

If you have any questions or comments please forward them to:

LAUNCH Tech USA

Product Support

Phone: 877-528-6249 xt: 4

E-mail: support@launchtechusa.com

Monday - Friday 5 am - 5 pm PST

Service & Repair

Phone: 877-528-6249 xt: 5

Monday - Friday 8 am - 5 pm PST

If your unit requires repair service, return it to the manufacturer with a copy of the sales receipt and a note describing the problem. If the unit is determined to be in warranty, it will be repaired or replaced at no charge. If the unit is determined to be out of warranty, it will be repaired for a nominal service charge plus return freight. Send the unit pre-paid to:

Attn: LAUNCH Tech USA
1820 South Milliken Ave.
Ontario, CA 91761